

NOTE:
 1. SEE DWG *PS-2014 REVA PG2* VEIW A-A FOR SCRAP CONV. TRANSFER DETAILS.
 2. SEE DWG *PS-2014 REVA PG3* FOR PLACEMENT PALLET SERVICES BLDG.

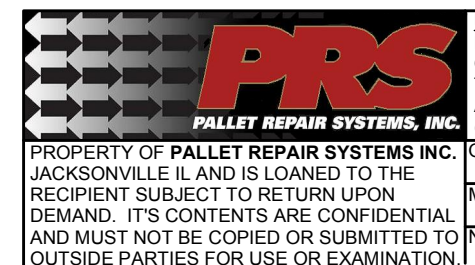

UNLESS OTHERWISE SPECIFIED DIM TOLERANCE: INCHES ONE PLACE: +/- .10 TWO PLACES: +/- .050 ANGLES: +/- 1 () INDICATES REF DIM	MATERIAL: PLANT LAYOUT	SCALE: NTS
	DRAWN BY: TDL DATE: 5-5-14	
QTY: MODEL: NEXT ASSY:	DESC: 	SHEET NO: 1 OF 3 PART NO: PS-2014 REV: A

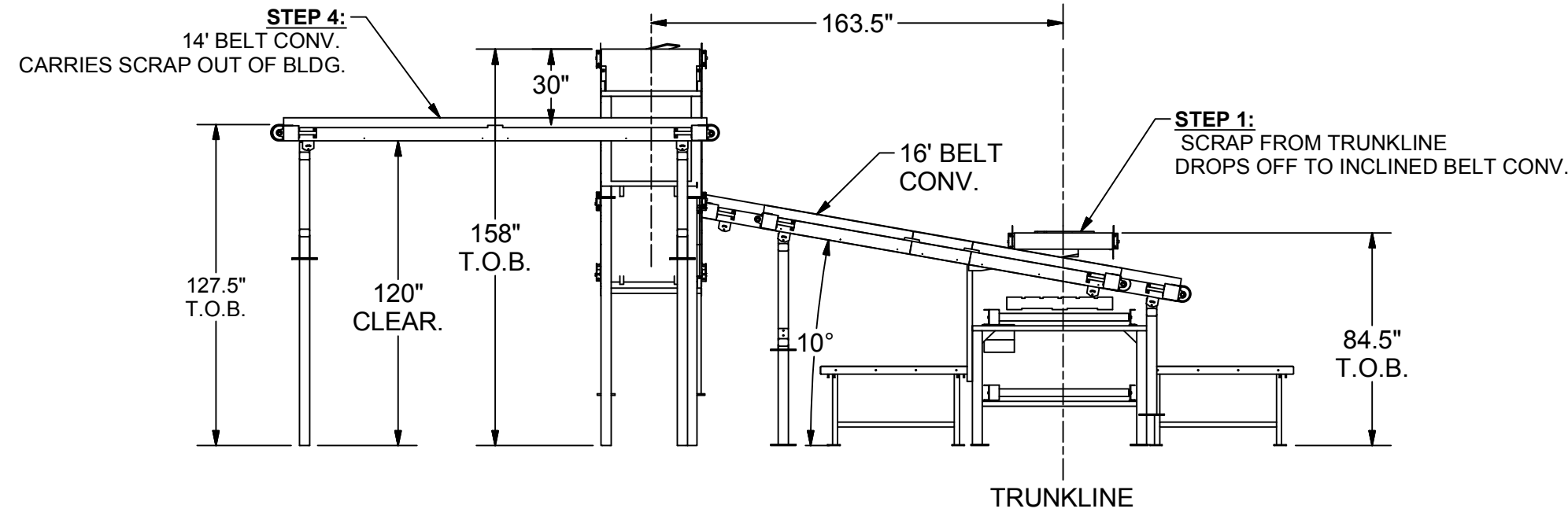
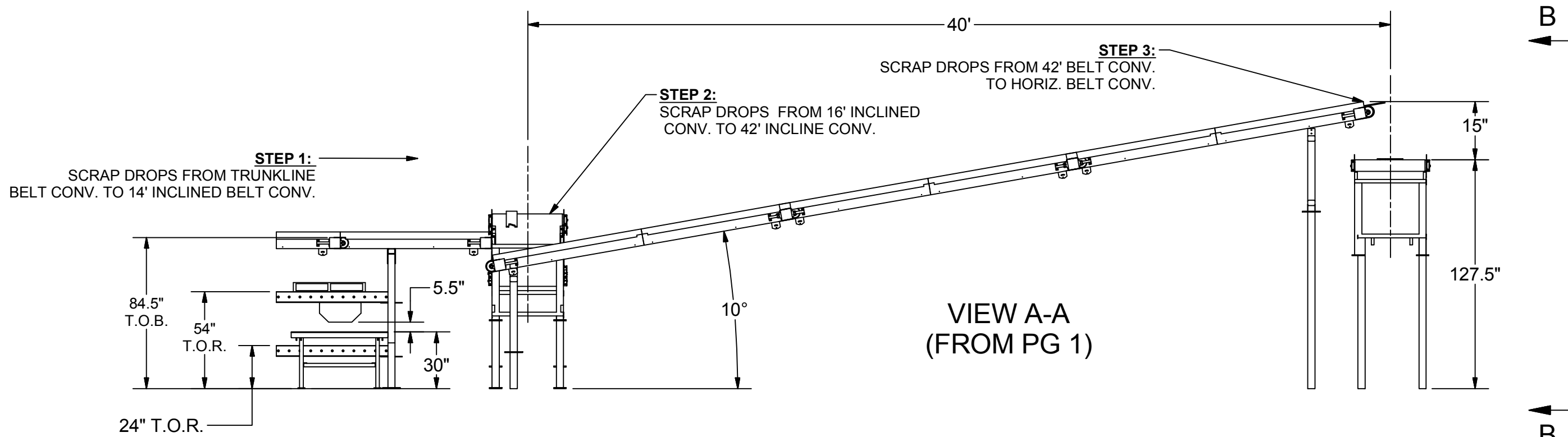

VIEW B-B



PROPERTY OF PALLET REPAIR SYSTEMS INC. JACKSONVILLE IL AND IS LOANED TO THE RECIPIENT SUBJECT TO RETURN UPON DEMAND. IT'S CONTENTS ARE CONFIDENTIAL AND MUST NOT BE COPIED OR SUBMITTED TO OUTSIDE PARTIES FOR USE OR EXAMINATION.

UNLESS OTHERWISE SPECIFIED
 DIM TOLERANCE: INCHES
 ONE PLACE: +/- .10
 TWO PLACES: +/- .050
 ANGLES: +/- 1
 () INDICATES REF DIM

QTY:
 MODEL:
 NEXT ASSY:

MATERIAL:	SCALE: NTS
DRAWN BY: TDL	DATE: 5-2-14
DESCP: PALLET TRANSFER DETAILS	
SHEET NO: 2 OF 3	PART NO: PS-2014
REV: A	

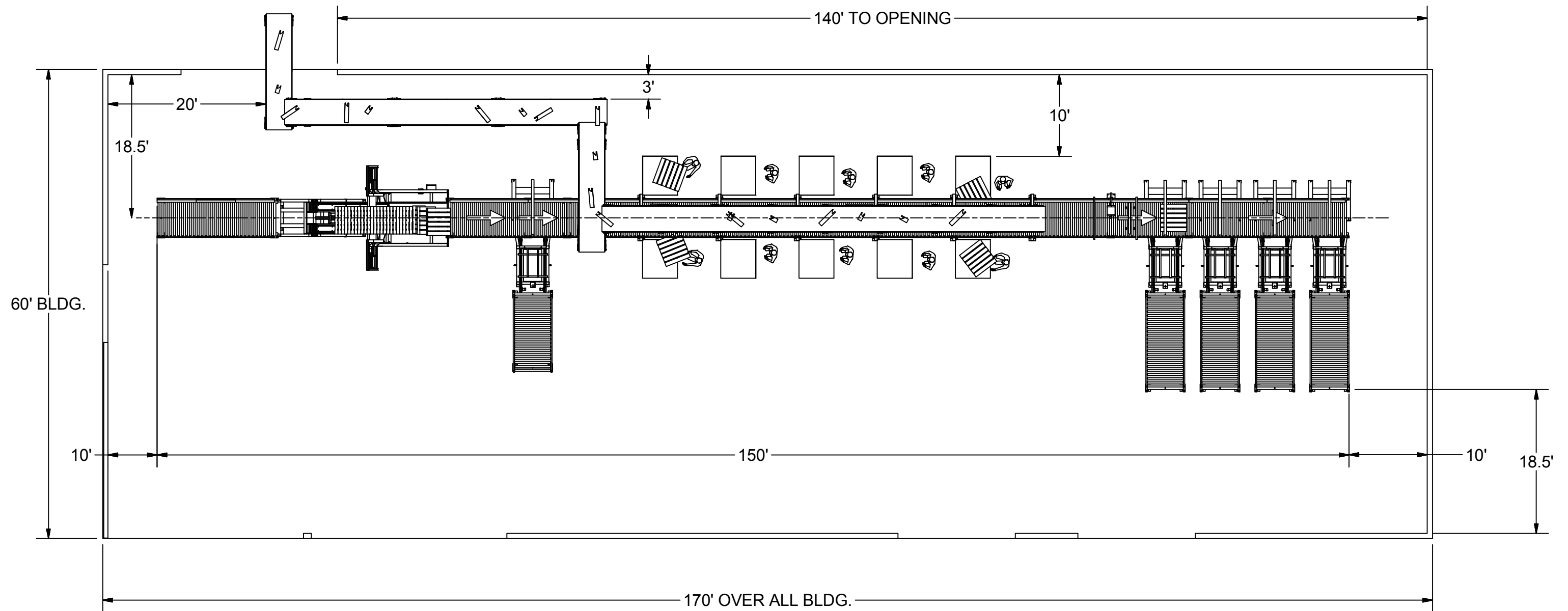

NOTE:
 1. DRAWING SHOWS PLACEMENT OF CONVEYOR SYSTEM PLACED IN BUILDING. DIMENSIONS ARE APPROX. DEPENDING ON SIZE OF CLIENTS EQUIPMENT AND OTHER MINOR VARIABLES.



PROPERTY OF PALLET REPAIR SYSTEMS INC. JACKSONVILLE IL AND IS LOANED TO THE RECIPIENT SUBJECT TO RETURN UPON DEMAND. IT'S CONTENTS ARE CONFIDENTIAL AND MUST NOT BE COPIED OR SUBMITTED TO OUTSIDE PARTIES FOR USE OR EXAMINATION.

UNLESS OTHERWISE SPECIFIED
 DIM TOLERANCE: INCHES
 ONE PLACE: +/- .10
 TWO PLACES: +/- .050
 ANGLES: +/- 1
 () INDICATES REF DIM

QTY:
 MODEL:
 NEXT ASSY:

MATERIAL:	PLANT LAYOUT	SCALE:	NTS
DRAWN BY:	TDL	DATE:	5-5-14
DESCP:	SYSTEM LAYOUT IN BLDG.		
SHEET NO:	3 OF 3	PART NO:	PS-2014
REV:			A